

REFUSE COLLECTOR

MODEL 2RK

REAR END LOADER

FOR INDUSTRIAL

CONTAINERS



ROS ROCA

Environmental
technology.



Rear end loader for industrial containers

The Ros Roca 2RK rear end loader has been designed for the collection of both industrial and bulky waste. The 3.2 m³ hopper combined with the large loading edge allows the fast absorption of waste, even with large containers. The low height of the loading edge allows the manual loading with the minimum effort.

Specifications

- Capacities from 22 to 28 m³.
- Horizontal ejector cylinder.
- Body with smooth sides.
- Front body locker with 600 mm height.
- 3.2 m³ hopper volume.
- 8 mm thickness hopper.
- Loading edge approx. 1.000mm.
- 20 mm thickness cutting edge of the packer plate.
- 150 mm of diameter working cylinder.
- 43.5 Tn press pressure working at 210 bar.
- Double-action telescopic cylinder.
- Ejector plates with central guides by slide blocks and side stabilizers.
- Adjustable counterpressure of the ejector plate.
- Ejection plate with perimetral watertight.
- Control panel in cabin with display and function switch.
- Unloading push buttons, in cabin and in one body side.
- Available different type of lifters.
- Certifications according to 98/97/CEE and EN-1501-1.
- Automatic compaction cycle, semiautomatic and manual, depending on the application.

Lifters

The 2RK rear end loader can be fitted with an industrial lifter for collecting large volume containers and with a lifter for standard containers.

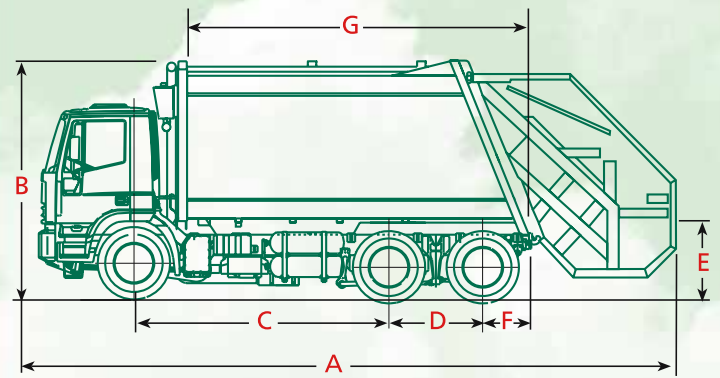

MODEL	CAPACITY (m ³)	G.V.W. (Tm)	A (mm)	B (mm)	C (mm)		D (mm)	E (mm)	F (mm)	G (mm)
					2 nd steering axle	3 rd steering axle				
2RK22	22	26	8.970	3.682	3.600	3.800	1.350	1.000	600	5.226
2RK23	23	26	9.170	3.682	3.800	-	1.350	1.000	600	5.476
2RK24	24	26	9.370	3.682	4.000	-	1.350	1.000	600	5.776
2RK25	25	26	9.570	3.682	4.200	-	1.350	1.000	600	6.026
2RK28	28	32	10.515	3.682	3.865		1.235+1.395	1.000	600	6.526

INDUSTRIAL LIFTER

Container type	2.5 m ³	5 m ³	Containers from 4,4 to 7m ³
Standard	EN 12574.1	EN 12574.1	-----
Cycle	45 seconds		
Lifting power	60 kN (6.000 kg)		
Stabilizers	2 telescopic stabilizers with a lift power of 13.500 Kg each one.		

MULTI-PORPOSE LIFTER

Container type	80l / 390l	500l / 1.200l	770l / 1.300l	Ochsner 800l
Standard	EN-840.1	EN-840.2	EN-840.3	-----
Clamp	Comb	Comb/Arms	Comb/Arms	Arms
Standard/optional	S	S	S	O
Cycle	12 seconds			
Lifting power	8 kN (800 kg)			



The Quality management system is applied to the design, production and sales of urban and industrial cleaning and sewerage systems.

Specifications subject to modification without prior notice. The illustrations may not correspond to standard versions of the units.



ROS ROCA S.A.

www.rosroca.com

Av. Cervera, s/n.
Ph.: +34 973 50 81 08 / 09
Fax: +34 973 50 81 32
25300 TÀRREGA (LLEIDA) SPAIN

e-mail: export@rosroca.com